

High Capacity Pancake Load Cell

- ▶ Low profile, high accuracy
- ▶ No field calibration required
- ▶ Welding plate for mounting to any leg style.
- ▶ High capacity (25,000/55,000 lb.)
- ▶ Lightning warranty

Specifications

Full Scale Output	3.0mv/V +/- .25% @ 55000 lb/24948 kg 3.0mv/V +/- .25% @ 25000 lb/11340 kg
Zero Balance	+/- 1% of rated output
Operating Temperature	-40° to 150° F (-40° to 65° C)
Temp Compensated Range	14° to 104° F (-10° to +40° C)
Material	Nickel plating - Electrophoretic Grey Coating
Cable length	30 ft w/ 5 pin HS connector
Warranty	1 year
Seal Type	IP69K (Hermetically Sealed)



BinTrac System

Bin weighing system includes: load cells, summing box and BinTrac indicator



- ▶ Current inventory by bin
- ▶ 24-hour usage for past 4 days
- ▶ Last 4 fill event weights for each bin
- ▶ Up to 4 bins per indicator

Easy Upgrade

Our pancake style load cells provide an alternative solution for high capacity applications where the bin can set directly on the assembly. More options with the same great quality, accuracy and reliability you expect from BinTrac.

Mounting Adapters

Adapters are available for different leg styles, providing easy installation on most bins. Typical mounting adapters are shown below. Contact BinTrac for additional options.

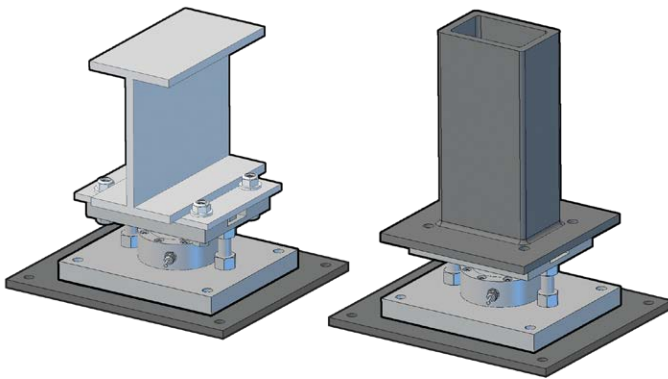

25,000 lbs. capacity model shown with mounting plates and weatherproof cable.

Superior Design

BinTrac high capacity pancake style load cells are configured to operate in compression, offering a very low profile design. The BinTrac design is temperature compensated, zeroed and hermetically sealed offering an IP69K protection class rating. The high reliability design protects against fatigue and side forces. The electrostatic paint finish makes it ideal for the extreme temperature and moisture conditions of rugged outdoor bin applications.

Bin Weighing Module Dimensions

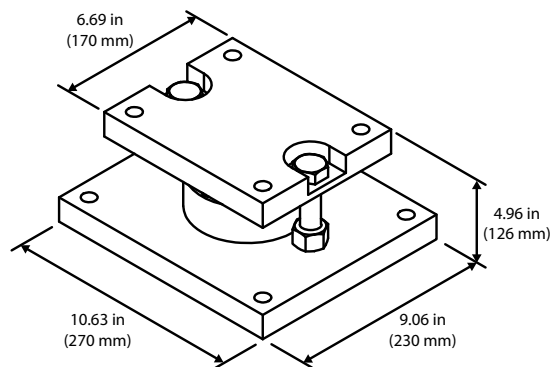

Dimensions with Mounting Plates

